



PANORAMA

BANCO pozzetti con riserva / 2 level built-in pozzetti COUNTER



CARATTERISTICHE TECNICHE	TECHNICAL SPECIFICATIONS	OPTIONAL	OPTIONALS
<ul style="list-style-type: none"> - vasca monoblocco schiumata in poliuretano iniettato a 40 kg/m³ - interno vasca in acciaio inox 18/10 AISI 304 - piletta di scarico vasca con tappo di chiusura per facilitare le operazioni di sbrinamento e di pulizia - 2 livelli di carapine H 250 mm - sistema anti-rotazione delle carapine - chiusura ermetica con ante in vetro piroclitico, temperato e riscaldato - illuminazione LED - refrigerazione ventilata - pannello comandi elettronico - sbrinamento manuale con arresto dell'impianto 	<ul style="list-style-type: none"> - carapine con sistema anti-rotazione - lavaporizzatore - motore remoto 	<ul style="list-style-type: none"> - monobloc foam tank insulated with injected polyurethane (40 kg/m³) - tank interior in 18/10 AISI 304 stainless steel - tank drains with plug to facilitate defrosting and cleaning operations - double level of 250 mm / 9.84" high gelato tubs - exclusive tubs anti-rotation system - tempered and heated airtight glass closure system - LED lighting - ventilated refrigeration system - electronic control panel - manual defrost function with system stoppage 	<ul style="list-style-type: none"> - tubs with anti-rotation system - scoop washer - remote condensing unit

SEZIONE SECTION VIEW

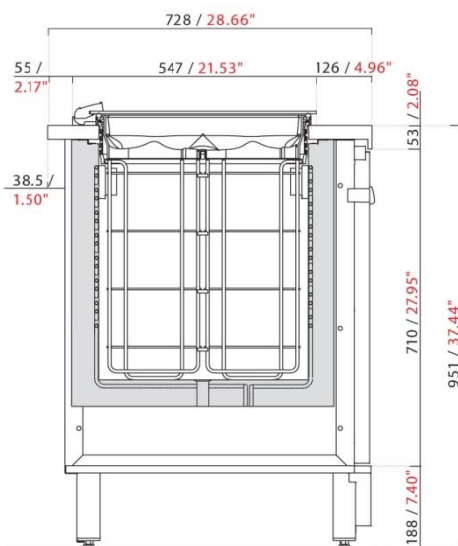

BANCO PANORAMA CON RISERVA

PANORAMA pozzetti counter with 2 levels of gelato tubs

DIMENSIONI, PESO E IMBALLO DIMENSIONS, WEIGHT AND PACKAGING

MODELLO MODEL	LUNGHEZZA con 2 fianchi LENGTH with 2 end panels		PROFONDITÀ DEPTH		PESO WEIGHT		DIMENSIONE IMBALLO PACKAGING DIMENSIONS		PESO con imballo CRATED WEIGHT	
	mm	in	mm	in	kg	lb	mm	in	kg	lb
L 750	810	31.89"	728	28.66"	45	100	1124x911xH1367	44.3"x35.9"xH53.8"	82	181
L 1000	1060	41.73"	728	28.66"	60	132	1124x911xH1367	44.3"x35.9"xH53.8"	97	214
L 1250	1310	51.57"	728	28.66"	75	165	1624x911xH1367	63.9"x35.9"xH53.8"	126	278
L 1500	1560	61.42"	728	28.66"	90	198	1624x911xH1367	63.9"x35.9"xH53.8"	141	311
L 1750	1810	71.26"	728	28.66"	105	231	2124x911xH1367	83.6"x35.9"xH53.8"	169	373
L 2000	2060	81.10"	728	28.66"	120	265	2124x911xH1367	83.6"x35.9"xH53.8"	184	406
L 2250	2310	90.94"	728	28.66"	135	298	2624x911xH1367	103.3"x35.9"xH53.8"	213	470
L 2500	2560	100.79"	728	28.66"	150	331	2624x911xH1367	103.3"x35.9"xH53.8"	228	503
L 3000	3060	120.47"	728	28.66"	180	397	3124x911xH1367	123"x35.9"xH53.8"	272	600
L 3500	3560	140.16"	728	28.66"	210	463	3724x1074xH1367	146.6"x42.3"xH53.8"	336	741
L 4000	4060	159.84"	728	28.66"	240	529	4224x1074xH1367	166.3"x42.3"xH53.8"	382	842

1 TEMPERATURA 1 TEMPERATURE

MODULI UC = con motore a bordo UC units = with built-in air-cooled condensing unit



MODULI NUC = con motore remoto NUC units = with remote condensing unit

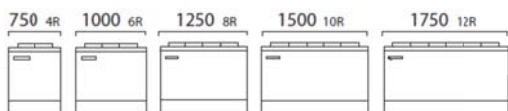

2 TEMPERATURE 2 TEMPERATURES

MODULI UC = con motore a bordo UC units = with built-in air-cooled condensing unit

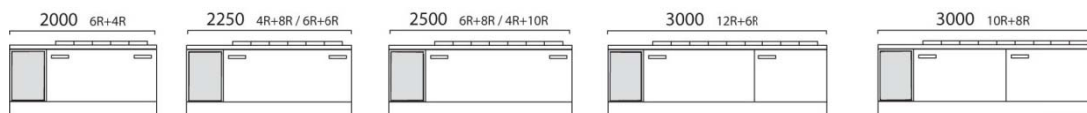

MODULI NUC = con motore remoto NUC units = with remote condensing unit

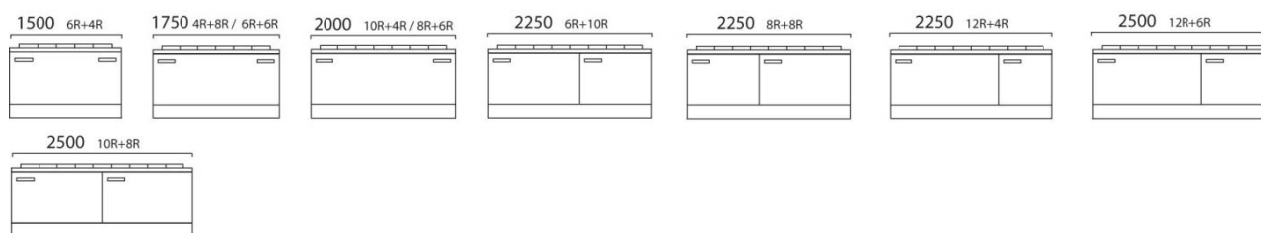

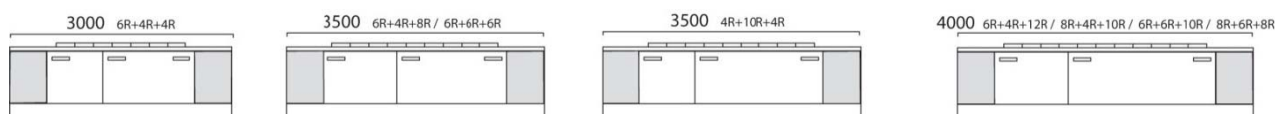

3 TEMPERATURE 3 TEMPERATURES

MODULI UC = con motore a bordo UC units = with built-in air-cooled condensing unit

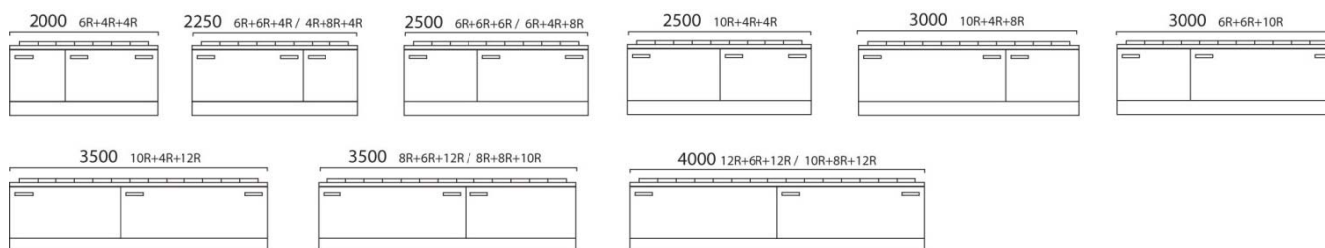

MODULI NUC = con motore remoto NUC units = with remote condensing unit





		UC = con motore a bordo UC = with built-in air-cooled condensing unit NUC = con motore remoto entro 10 metri NUC = with condensing unit within 20 meters				TENSIONE E FREQUENZA VOLTAGE AND FREQUENCY V/Ph/Hz 208-220/1/60				
MODELLO MODEL	POTENZA COMP. HP	BREAKER SIZE	MCA	MOP	RESA CAPACITY	CLASSE CLIMATICA CLIMATE CLASS			TEMPERATURA DI ESERCIZIO OPERATING TEMPERATURE	
1 TEMPERATURA 1 TEMPERATURE	HP	A	A	A	W/h -30°C BTU/h -22°F	°C	°F	U.R. R.H.	°C	°F
4 pozzetti	1/2	8	7	10	460 1.569	30°C	86°F	55%	-2°C; -18°C	+28.4°F; -0.4°F
6 pozzetti	1/2	8	7	10	460 1.569	30°C	86°F	55%	-2°C; -18°C	+28.4°F; -0.4°F
8 pozzetti	5/8	8	6	8	502 1.712	30°C	86°F	55%	-2°C; -18°C	+28.4°F; -0.4°F
10 pozzetti	5/8	8	6	9	502 1.712	30°C	86°F	55%	-2°C; -18°C	+28.4°F; -0.4°F
12 pozzetti	5/8	8	6	9	502 1.712	30°C	86°F	55%	-2°C; -18°C	+28.4°F; -0.4°F

		UC = con motore a bordo UC = with built-in air-cooled condensing unit NUC = con motore remoto entro 10 metri NUC = with condensing unit within 20 meters				TENSIONE E FREQUENZA VOLTAGE AND FREQUENCY V/Ph/Hz 208-220/1/60				
MODELLO MODEL	POTENZA COMP. HP	BREAKER SIZE	MCA	MOP	RESA CAPACITY	CLASSE CLIMATICA CLIMATE CLASS			TEMPERATURA DI ESERCIZIO OPERATING TEMPERATURE	
2 TEMPERATURE 2 TEMPERATURES	HP	A	A	A	W/h -30°C BTU/h -22°F	°C	°F	U.R. R.H.	°C	°F
6+4 pozzetti	5/8	8	6	9	502 1.712	30°C	86°F	55%	-2°C; -18°C	+28.4°F; -0.4°F
6+6 pozzetti	5/8	8	6	9	502 1.712	30°C	86°F	55%	-2°C; -18°C	+28.4°F; -0.4°F
4+8 pozzetti	5/8	8	6	9	502 1.712	30°C	86°F	55%	-2°C; -18°C	+28.4°F; -0.4°F
4+10 pozzetti	1,2	10	8	12	925 3.154	30°C	86°F	55%	-2°C; -18°C	+28.4°F; -0.4°F
6+8 pozzetti	1,2	10	8	12	925 3.154	30°C	86°F	55%	-2°C; -18°C	+28.4°F; -0.4°F
6+10 pozzetti	1,2	10	9	12	925 3.154	30°C	86°F	55%	-2°C; -18°C	+28.4°F; -0.4°F
8+8 pozzetti	1,2	10	9	12	925 3.154	30°C	86°F	55%	-2°C; -18°C	+28.4°F; -0.4°F
10+4 pozzetti	1,2	10	8	12	925 3.154	30°C	86°F	55%	-2°C; -18°C	+28.4°F; -0.4°F
10+8 pozzetti	1,2	10	9	12	925 3.154	30°C	86°F	55%	-2°C; -18°C	+28.4°F; -0.4°F
12+4 pozzetti	1,2	10	9	12	925 3.154	30°C	86°F	55%	-2°C; -18°C	+28.4°F; -0.4°F
12+6 pozzetti	1,2	10	9	12	925 3.154	30°C	86°F	55%	-2°C; -18°C	+28.4°F; -0.4°F

		UC = con motore a bordo UC = with built-in air-cooled condensing unit NUC = con motore remoto entro 10 metri NUC = with condensing unit within 20 meters				TENSIONE E FREQUENZA VOLTAGE AND FREQUENCY V/Ph/Hz 208-220/1/60				
MODELLO MODEL	POTENZA COMP. HP	BREAKER SIZE	MCA	MOP	RESA CAPACITY	CLASSE CLIMATICA CLIMATE CLASS			TEMPERATURA DI ESERCIZIO OPERATING TEMPERATURE	
3 TEMPERATURE 3 TEMPERATURES	HP	A	A	A	W/h -30°C BTU/h -22°F	°C	°F	U.R. R.H.	°C	°F
*6+4+4 pozzetti	5/8+1/2	8+8	6+7	9+10	502+460 1.712+1.569	30°C	86°F	55%	-2°C; -18°C	+28.4°F; -0.4°F
*4+8+4 pozzetti	5/8+1/2	8+8	6+7	9+10	502+460 1.712+1.569	30°C	86°F	55%	-2°C; -18°C	+28.4°F; -0.4°F
*6+6+4 pozzetti	5/8+1/2	8+8	6+7	9+10	502+460 1.712+1.569	30°C	86°F	55%	-2°C; -18°C	+28.4°F; -0.4°F
*6+6+6 pozzetti	5/8+1/2	8+8	6+7	9+10	502+460 1.712+1.569	30°C	86°F	55%	-2°C; -18°C	+28.4°F; -0.4°F
*6+4+8 pozzetti	5/8+5/8	8+8	6+6	9+8	502+502 1.712+1.712	30°C	86°F	55%	-2°C; -18°C	+28.4°F; -0.4°F
*4+10+4 pozzetti	1,2+1/2	10+8	8+7	12+10	925+460 3.154+1.569	30°C	86°F	55%	-2°C; -18°C	+28.4°F; -0.4°F
*10+4+4 pozzetti	1,2+1/2	10+8	8+7	12+10	925+460 3.154+1.569	30°C	86°F	55%	-2°C; -18°C	+28.4°F; -0.4°F
*10+4+8 pozzetti	1,2+5/8	10+8	8+6	12+8	925+502 3.154+1.712	30°C	86°F	55%	-2°C; -18°C	+28.4°F; -0.4°F
*6+4+12 pozzetti	5/8+5/8	8+8	6+6	9+9	502+502 1.712+1.712	30°C	86°F	55%	-2°C; -18°C	+28.4°F; -0.4°F
*6+6+10 pozzetti	5/8+5/8	8+8	6+6	9+9	502+502 1.712+1.712	30°C	86°F	55%	-2°C; -18°C	+28.4°F; -0.4°F
*8+4+10 pozzetti	1,2+5/8	8+8	6+6	9+8	502+502 1.712+1.712	30°C	86°F	55%	-2°C; -18°C	+28.4°F; -0.4°F
*8+6+8 pozzetti	1,2+5/8	10+8	8+6	12+8	925+502 3.154+1.712	30°C	86°F	55%	-2°C; -18°C	+28.4°F; -0.4°F
*10+4+12 pozzetti	1,2+5/8	10+8	8+6	12+9	925+502 3.154+1.712	30°C	86°F	55%	-2°C; -18°C	+28.4°F; -0.4°F
*8+6+12 pozzetti	1,2+5/8	10+8	9+6	12+9	925+502 3.154+1.712	30°C	86°F	55%	-2°C; -18°C	+28.4°F; -0.4°F
*8+8+10 pozzetti	1,2+5/8	10+8	9+6	12+9	925+502 3.154+1.712	30°C	86°F	55%	-2°C; -18°C	+28.4°F; -0.4°F
*12+6+12 pozzetti	1,2+5/8	10+8	9+6	12+9	925+502 3.154+1.712	30°C	86°F	55%	-2°C; -18°C	+28.4°F; -0.4°F
*10+8+12 pozzetti	1,2+5/8	10+8	9+6	12+9	925+502 3.154+1.712	30°C	86°F	55%	-2°C; -18°C	+28.4°F; -0.4°F

*2 compressori / 2 allacci elettrici *2 condensing units / 2 electrical connections

		UC CON MOTORE A BORDO WITH BUILT-IN AIR-COOLED CONDENSING UNIT				TENSIONE E FREQUENZA VOLTAGE AND FREQUENCY				
						MONOFASE - V/Ph/Hz 230/1/50				
MODELLO MODEL	POTENZA ASSORBITA CURRENT CONSUMPTION		RESA COOLING CAPACITY		CLASSE CLIMATICA CLIMATE CLASS			TEMPERATURA DI ESERCIZIO OPERATING TEMPERATURE		
1 TEMPERATURA 1 TEMPERATURES	monofase 230/1/50		monofase 230/1/50		°C	°F	U.R. R.H.	°C	°F	
	W	A	W/h -30°C	BTU/h -22°F						
L 1250 UC - 4 pozzetti	504	3.25	460	1.570	30°C	86°F	55%	-2°C; -18°C	+28.4°F; -0.4°F	
L 1500 UC - 6 pozzetti	545	3.43	460	1.570	30°C	86°F	55%	-2°C; -18°C	+28.4°F; -0.4°F	
L 1750 UC - 8 pozzetti	746	3.95	615	2.100	30°C	86°F	55%	-2°C; -18°C	+28.4°F; -0.4°F	
L 2000 UC - 10 pozzetti	792	4.15	615	2.100	30°C	86°F	55%	-2°C; -18°C	+28.4°F; -0.4°F	
L 2250 UC - 12 pozzetti	838	4.35	615	2.100	30°C	86°F	55%	-2°C; -18°C	+28.4°F; -0.4°F	

		UC CON MOTORE A BORDO WITH BUILT-IN AIR-COOLED CONDENSING UNIT				TENSIONE E FREQUENZA VOLTAGE AND FREQUENCY				
						MONOFASE - V/Ph/Hz 230/1/50				
MODELLO MODEL	POTENZA ASSORBITA CURRENT CONSUMPTION		RESA COOLING CAPACITY		CLASSE CLIMATICA CLIMATE CLASS			TEMPERATURA DI ESERCIZIO OPERATING TEMPERATURE		
2 TEMPERATURE 2 TEMPERATURES	monofase 230/1/50		monofase 230/1/50		°C	°F	U.R. R.H.	°C	°F	
	W	A	W/h -30°C	BTU/h -22°F						
L 2000 UC - 6+4 pozzetti	792	4.15	615	2.100	30°C	86°F	55%	-2°C; -18°C	+28.4°F; -0.4°F	
L 2250 UC - 6+6 pozzetti	838	4.35	615	2.100	30°C	86°F	55%	-2°C; -18°C	+28.4°F; -0.4°F	
L 2250 UC - 4+8 pozzetti	838	4.35	615	2.100	30°C	86°F	55%	-2°C; -18°C	+28.4°F; -0.4°F	
L 2500 UC - 4+10 pozzetti	1037	5.02	925	3.154	30°C	86°F	55%	-2°C; -18°C	+28.4°F; -0.4°F	
L 2500 UC - 6+8 pozzetti	1037	5.02	925	3.154	30°C	86°F	55%	-2°C; -18°C	+28.4°F; -0.4°F	
L 2500 UC - 12+6 pozzetti	1118	5.38	925	3.154	30°C	86°F	55%	-2°C; -18°C	+28.4°F; -0.4°F	
L 2500 UC - 10+8 pozzetti	1118	5.38	925	3.154	30°C	86°F	55%	-2°C; -18°C	+28.4°F; -0.4°F	

		UC CON MOTORE A BORDO WITH BUILT-IN AIR-COOLED CONDENSING UNIT				TENSIONE E FREQUENZA VOLTAGE AND FREQUENCY				
						MONOFASE - V/Ph/Hz 230/1/50				
MODELLO MODEL	POTENZA ASSORBITA CURRENT CONSUMPTION		RESA COOLING CAPACITY		CLASSE CLIMATICA CLIMATE CLASS			TEMPERATURA DI ESERCIZIO OPERATING TEMPERATURE		
3 TEMPERATURE 3 TEMPERATURES	monofase 230/1/50		monofase 230/1/50		°C	°F	U.R. R.H.	°C	°F	
	W	A	W/h -30°C	BTU/h -22°F						
* L 3000 UC - 6+4+4 pozzetti	1296	7.40	615+460	2.100+1.569	30°C	86°F	55%	-2°C; -18°C	+28.4°F; -0.4°F	
* L 3500 UC - 6+4+8 pozzetti	1538	8.10	615+615	2.100+2.100	30°C	86°F	55%	-2°C; -18°C	+28.4°F; -0.4°F	
* L 3500 UC - 6+6+6 pozzetti	1383	7.78	615+460	2.100+1.569	30°C	86°F	55%	-2°C; -18°C	+28.4°F; -0.4°F	
* L 3500 UC - 4+10+4 pozzetti	1541	8.27	925+460	3.154+1.569	30°C	86°F	55%	-2°C; -18°C	+28.4°F; -0.4°F	
* L 4000 UC - 6+4+12 pozzetti	1630	8.50	615+615	2.100+2.100	30°C	86°F	55%	-2°C; -18°C	+28.4°F; -0.4°F	
* L 4000 UC - 8+4+10 pozzetti	1630	8.50	615+615	2.100+2.100	30°C	86°F	55%	-2°C; -18°C	+28.4°F; -0.4°F	
* L 4000 UC - 6+6+10 pozzetti	1630	8.50	615+615	2.100+2.100	30°C	86°F	55%	-2°C; -18°C	+28.4°F; -0.4°F	
* L 4000 UC - 8+6+8 pozzetti	1783	8.97	925+615	3.154+2.100	30°C	86°F	55%	-2°C; -18°C	+28.4°F; -0.4°F	

*2 compressori / 2 allacci elettrici *2 condensing units / 2 electrical connections

	CON MOTORE ENTRO 20 METRI WITH CONDENSING UNIT WITHIN 20 METERS				TENSIONE E FREQUENZA VOLTAGE AND FREQUENCY				
					MONOFASE - V/Ph/Hz 230/1/50				
MODELLO MODEL	POTENZA ASSORBITA CURRENT CONSUMPTION		RESA COOLING CAPACITY		CLASSE CLIMATICA CLIMATE CLASS			TEMPERATURA DI ESERCIZIO OPERATING TEMPERATURE	
1 TEMPERATURA 1 TEMPERATURES	monofase 230/1/50		monofase 230/1/50		°C	°F	U.R. R.H.	°C	°F
	W	A	W/h -30°C	BTU/h -22°F					
L 750 NUC - 4 pozzetti	629	3.35	615	2.100	30°C	86°F	55%	-2°C; -18°C	+28.4°F; -0.4°F
L 1000 NUC - 6 pozzetti	670	3.53	615	2.100	30°C	86°F	55%	-2°C; -18°C	+28.4°F; -0.4°F
L 1250 NUC - 8 pozzetti	720	3.75	615	2.100	30°C	86°F	55%	-2°C; -18°C	+28.4°F; -0.4°F
L 1500 NUC - 10 pozzetti	862	3.20	925	3.154	30°C	86°F	55%	-2°C; -18°C	+28.4°F; -0.4°F
L 1750 NUC - 12 pozzetti	908	3.40	925	3.154	30°C	86°F	55%	-2°C; -18°C	+28.4°F; -0.4°F

	CON MOTORE ENTRO 20 METRI WITH CONDENSING UNIT WITHIN 20 METERS				TENSIONE E FREQUENZA VOLTAGE AND FREQUENCY				
					MONOFASE - V/Ph/Hz 230/1/50				
MODELLO MODEL	POTENZA ASSORBITA CURRENT CONSUMPTION		RESA COOLING CAPACITY		CLASSE CLIMATICA CLIMATE CLASS			TEMPERATURA DI ESERCIZIO OPERATING TEMPERATURE	
2 TEMPERATURE 2 TEMPERATURES	monofase 230/1/50		monofase 230/1/50		°C	°F	U.R. R.H.	°C	°F
	W	A	W/h -30°C	BTU/h -22°F					
L 1500 NUC - 6+4 pozzetti	862	3.20	925	3.154	30°C	86°F	55%	-2°C; -18°C	+28.4°F; -0.4°F
L 1750 NUC - 6+6 pozzetti	908	3.40	925	3.154	30°C	86°F	55%	-2°C; -18°C	+28.4°F; -0.4°F
L 1750 NUC - 4+8 pozzetti	908	3.40	925	3.154	30°C	86°F	55%	-2°C; -18°C	+28.4°F; -0.4°F
L 2000 NUC - 10+4 pozzetti	947	3.57	925	3.154	30°C	86°F	55%	-2°C; -18°C	+28.4°F; -0.4°F
L 2000 NUC - 8+6 pozzetti	947	3.57	925	3.154	30°C	86°F	55%	-2°C; -18°C	+28.4°F; -0.4°F
L 2250 NUC - 8+8 pozzetti	988	3.75	925	3.154	30°C	86°F	55%	-2°C; -18°C	+28.4°F; -0.4°F
L 2250 NUC - 6+10 pozzetti	988	3.75	925	3.154	30°C	86°F	55%	-2°C; -18°C	+28.4°F; -0.4°F
L 2250 NUC - 12+4 pozzetti	988	3.75	925	3.154	30°C	86°F	55%	-2°C; -18°C	+28.4°F; -0.4°F
L 2500 NUC - 12+6 pozzetti	1028	3.93	925	3.154	30°C	86°F	55%	-2°C; -18°C	+28.4°F; -0.4°F
L 2500 NUC - 10+8 pozzetti	1028	3.93	925	3.154	30°C	86°F	55%	-2°C; -18°C	+28.4°F; -0.4°F

	CON MOTORE ENTRO 20 METRI WITH CONDENSING UNIT WITHIN 20 METERS				TENSIONE E FREQUENZA VOLTAGE AND FREQUENCY				
					MONOFASE - V/Ph/Hz 230/1/50				
MODELLO MODEL	POTENZA ASSORBITA CURRENT CONSUMPTION		RESA COOLING CAPACITY		CLASSE CLIMATICA CLIMATE CLASS			TEMPERATURA DI ESERCIZIO OPERATING TEMPERATURE	
3 TEMPERATURE 3 TEMPERATURES	monofase 230/1/50		monofase 230/1/50		°C	°F	U.R. R.H.	°C	°F
	W	A	W/h -30°C	BTU/h -22°F					
* L 2000 NUC - 6+4+4	1491	7.45	925+615	3.154+2.100	30°C	86°F	55%	-2°C; -18°C	+28.4°F; -0.4°F
* L 2250 NUC - 6+6+4	1537	7.65	925+615	3.154+2.100	30°C	86°F	55%	-2°C; -18°C	+28.4°F; -0.4°F
* L 2250 NUC - 4+8+4	1537	7.65	925+615	3.154+2.100	30°C	86°F	55%	-2°C; -18°C	+28.4°F; -0.4°F
* L 2500 NUC - 6+6+6	1578	7.83	925+615	3.154+2.100	30°C	86°F	55%	-2°C; -18°C	+28.4°F; -0.4°F
* L 2500 NUC - 6+4+8	1582	7.85	925+615	3.154+2.100	30°C	86°F	55%	-2°C; -18°C	+28.4°F; -0.4°F
* L 2500 NUC - 10+4+4	1576	7.82	925+615	3.154+2.100	30°C	86°F	55%	-2°C; -18°C	+28.4°F; -0.4°F
* L 3000 NUC - 10+4+8	1667	7.32	925+615	3.154+2.100	30°C	86°F	55%	-2°C; -18°C	+28.4°F; -0.4°F
* L 3000 NUC - 6+6+10	1770	6.60	925+925	3.154+3.154	30°C	86°F	55%	-2°C; -18°C	+28.4°F; -0.4°F
* L 3500 NUC - 10+4+12	1855	6.97	925+925	3.154+3.154	30°C	86°F	55%	-2°C; -18°C	+28.4°F; -0.4°F
* L 3500 NUC - 8+6+12	1855	6.97	925+925	3.154+3.154	30°C	86°F	55%	-2°C; -18°C	+28.4°F; -0.4°F
* L 3500 NUC - 8+8+10	1850	6.95	925+925	3.154+3.154	30°C	86°F	55%	-2°C; -18°C	+28.4°F; -0.4°F
* L 4000 NUC - 12+6+12	1936	7.33	925+925	3.154+3.154	30°C	86°F	55%	-2°C; -18°C	+28.4°F; -0.4°F
* L 4000 NUC - 10+8+12	1936	7.33	925+925	3.154+3.154	30°C	86°F	55%	-2°C; -18°C	+28.4°F; -0.4°F

*2 compressori / 2 allacci elettrici *2 condensing units / 2 electrical connections